



FA-2 series

Spin-on, tank top return filters



Technical Information

Housing

Pressure: **Max working** 12 bar (175 psi) (acc. to NFPA T 3.10.17)
Burst 20 bar (290 psi) (acc. to NFPA T 3.10.17)

Connection Ports: 3/4" ÷ 1 1/2" BSP

Materials: Head: aluminium alloy
Bowl: steel
Seal: Buna-N

By-pass: 1,7 bar (24.6 psi) setting

N.B. Cartridge with integrated bypass valve and antidrainback membrane

Element

Filter Media: Microglass fiber 4,5 - 7 - 12 - 27 $\mu\text{m}_{(c)}$ (acc. to ISO 16889)

Cellulose 10 - 25 $\mu\text{m}_{(c)}$ (acc. to ISO 16889)

Wire mesh 60 - 125 μm

Differential collapse pressure: 4 bar (58 psi) (acc. to ISO 2941)

Filtrec elements are tested also according to ISO 2942, ISO 23181 and ISO 3968

Common

Working temperature: -25°C +120°C (-13°F +248°F)

Fluid compatibility (acc. to ISO 2943):

Full with HH-HL-HM-HV (acc. to ISO 6743/4).

For use with other fluid applications please contact Filtrec Customer Service (info@filtrec.it).

Ordering information

MEDIA	
000	no element
G03	microglass fiber $\beta_{4,5 \mu\text{m (c)}} \geq 1000$
G06	microglass fiber $\beta_{7 \mu\text{m (c)}} \geq 1000$
G10	microglass fiber $\beta_{12 \mu\text{m (c)}} \geq 1000$
G25	microglass fiber $\beta_{27 \mu\text{m (c)}} \geq 1000$
C10	cellulose $\beta_{10 \mu\text{m (c)}} \geq 2$
C25	cellulose $\beta_{25 \mu\text{m (c)}} \geq 2$
T60	wire mesh 60 μm
T125	wire mesh 125 μm

	NOMINAL SIZE	MEDIA		SEALS	CONNECTION	INDICATOR
Filter assembly FA-2	21	C10	BM	B	B7	R2
Filter element A2	21	C10	BM			

SEALS	
B	NBR

CONNECTION	
B4	3/4" BSP (size 10-11)
B7	1 1/2" BSP (size 20-21)

INDICATOR	
00	no indicator
R2	pressure switch 1,3 bar N.O. / 18,9 psi
R3	pressure switch 1,3 bar N.C. / 18,9 psi
R6	visual pressure gauge 1,3 bar / 18,9 psi
R7	pressure/vacuum gauge -1 ÷ 5 bar / -14,5 ÷ 72,5 psi
R9	pressure gauge 0 ÷ 4 bar / 0 ÷ 58 psi

Preferential option

Overall dimensions

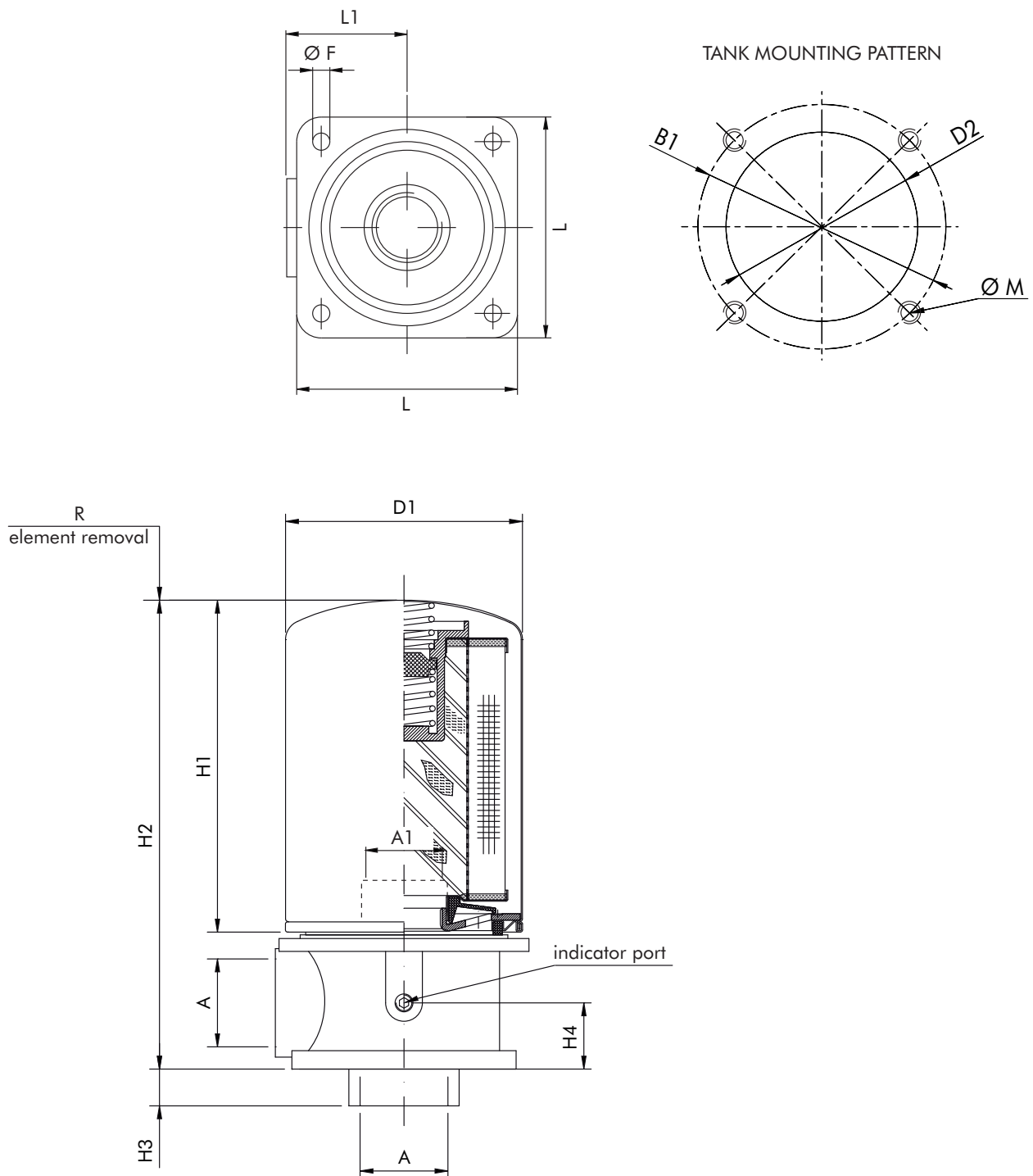

Nominal size

CODE	A	B1	D1	D2	Ø F	H1	H2	H3	H4	L	L1	Ø M	R	WEIGHT	ELEMENT	H1	A1
FA-2-10	3/4" BSP	99	96	40÷45	7	148	200	15	25	90	50	M6	20	1,3 Kg	A-2-10	148	3/4" BSP
FA-2-11						213	265							1,6 Kg	A-2-11	213	
FA-2-20	1 1/2" BSP	141	128	65÷70	9	182	255	20	36	122	70	M8	40	2,1 Kg	A-2-20	182	1 1/4" BSP
FA-2-21						228	300							2,3 Kg	A-2-21	228	

Pressure drop diagrams

The total Pressure Drop (Δp) value is obtained by adding the Δp values of filter housing and filter element at the given flow rate. This ideally should not exceed 0,5 bar (8 psi).

PRESSURE DROP THROUGH THE FILTER HOUSING

The Pressure Drop through the filter housing is governed by the port, not the bowl length and the oil viscosity.

PRESSURE DROP THROUGH THE CLEAN FILTER ELEMENT

The Pressure Drop through the filter element is related both to the internal diameter of the filter element and to the filter media; this value is affected by the oil viscosity in a roughly proportional way: e.g. when the D_p value from the curve is 0,2 bar and a 46 cSt oil is used, the corresponding value is 0,31 ($=0,2 \times 46/30$) bar.

Housing FA-2-10/11/20/21

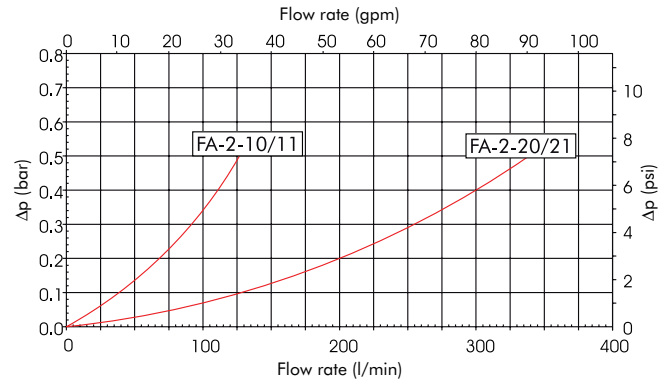

Element A-2-10

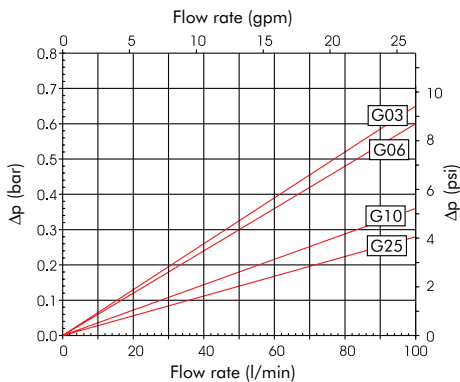

Element A-2-10

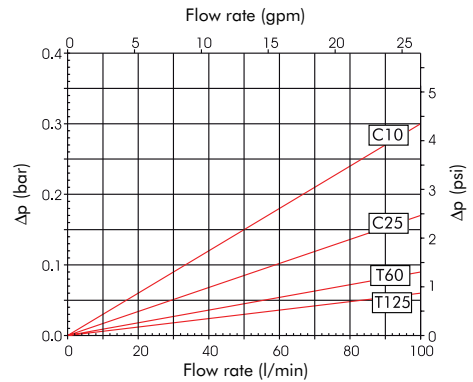

Element A-2-11

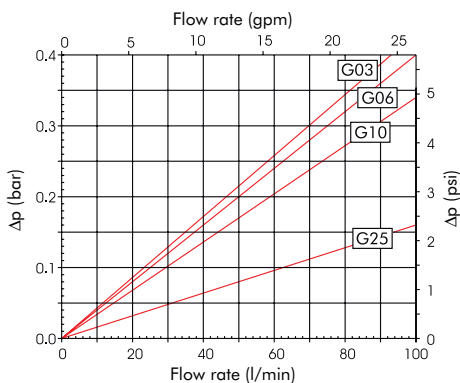

Element A-2-11

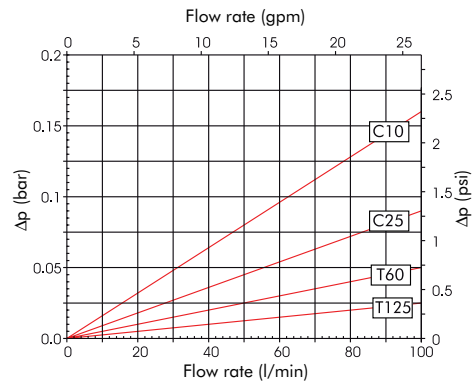

Element A-2-20

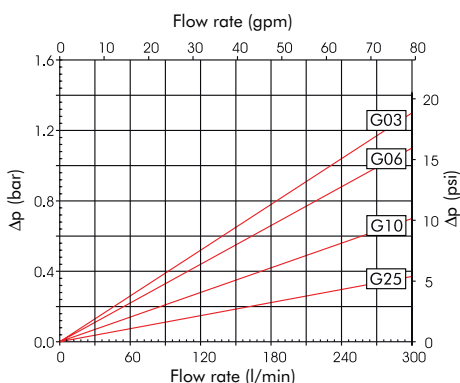

Element A-2-20

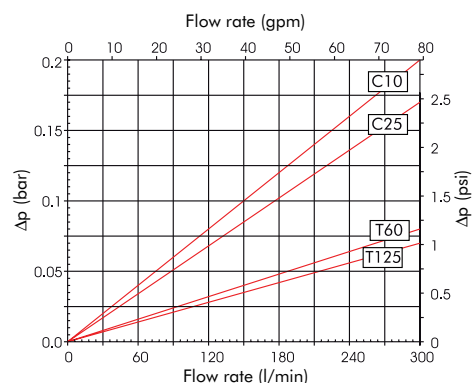

Pressure drop diagrams

Element A-2-21

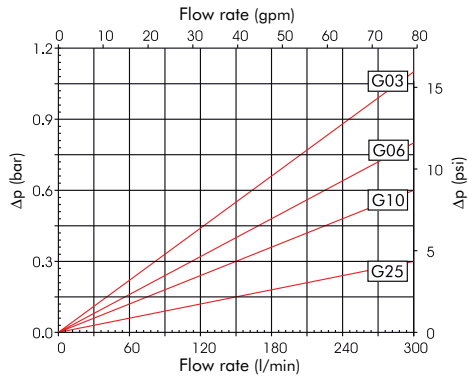

PRESSURE DROP THROUGH THE BY-PASS VALVE

The by-pass valve is a safety device to prevent element collapse in case of differential pressure peaks due to flow peaks, cold start conditions or when the clogged element is not replaced in a timely manner.

Element A-2-21

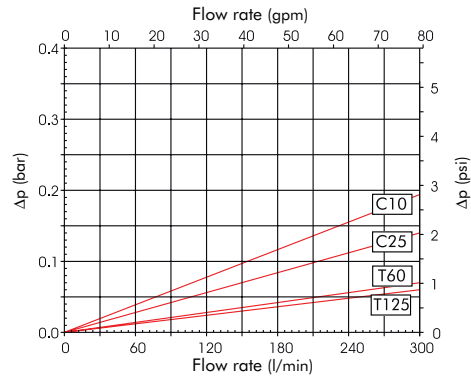

By-pass FA-2-10/11/20/21

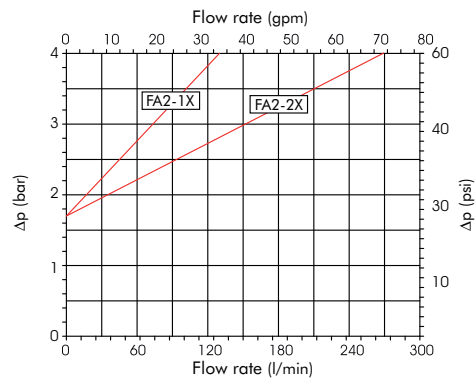

The above diagrams have been obtained at the FILTREC laboratory, according to the ISO 3968 specification, with mineral oil having 30 cSt viscosity and 0,86 Kg/dm³ density.

In case of discrepancy, please check contamination level, viscosity and features of the oil in use and the sampling points of the differential pressure.

Clogging indicator

The Pressure Drop (Δp) through the filter increases during the system operation due to the contaminant retained by the filter element.

The filter element must be replaced when the indicator shows an alarm and before the Δp reaches the by-pass value setting.

N.B. in cold start conditions a false alarm can be caused by higher oil viscosity due to low temperature; the indicator alarm must be considered at normal working temperature only.

The clogging indicator registers the pressure upstream the filter element:

- with the VISUAL indicator a value higher than 1,3 bar indicates the need of element replacement.
- with the ELECTRIC indicator an electrical switch is activated when the set value 1,3 bar is reached.

PRESSURE SWITCH

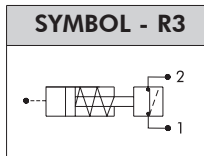
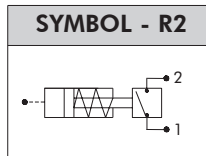
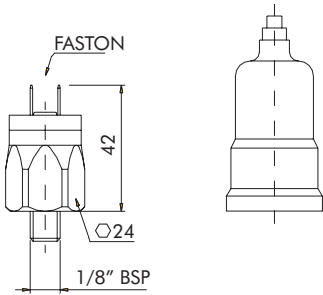

CODE	SETTING
R2	1,3 bar (18,9 psi) N.O.
R3	1,3 bar (18,9 psi) N.C.

- Current: 0,5 A resistive/ 0,2 A inductive
- Max voltage: 30-48 V DC
- Protection: IP54 as per DIN 40050

VISUAL PRESSURE GAUGE

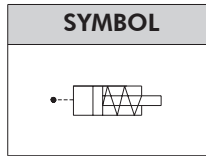
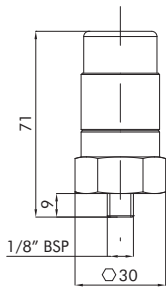

CODE	SETTING
R6	1,3 bar (18,9 psi)

PRESSURE/ VACUUM GAUGE

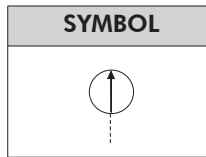
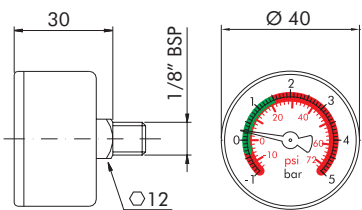

CODE	SCALE
R7	0 ÷ 1,4 bar (0 ÷ 20 psi) green sector
	1,4 ÷ 5 bar (20 ÷ 72,5 psi) red sector

Housing in black ABS material

N.B. Multipurpose product: this gauge can also be used as vacuum gauge on suction filters.

PRESSURE GAUGE

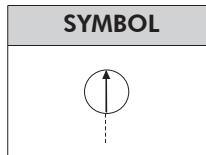
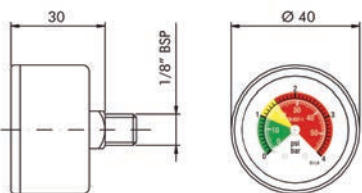

CODE	SCALE
R9	0 ÷ 1 bar (0 ÷ 14,5 psi) green sector
	1 ÷ 1,5 bar (14,5 ÷ 22 psi) yellow sector
	1,5 ÷ 4 bar (22 ÷ 58 psi) red sector

Housing in black ABS material

Preferential option

User Tips

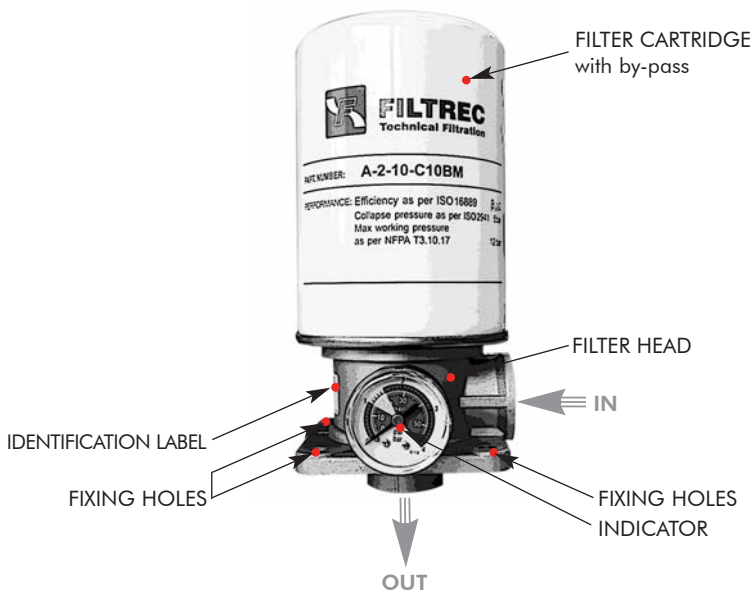

BOWL TIGHTENING TORQUE	
FA-2-xx	3/4 turn

INDICATOR TIGHTENING TORQUE	
R2/R3/R4/R6/R7/R9	30 Nm

Installation

Make sure that the filter flange is well secured on the tank lid through the fixing holes and that the hose is properly connected to the IN port; verify that the OUT port is clear (in this port an extension tube can be screwed, so that the outlet is below the oil level). After mounting verify that no tension is present on the filter.

Make sure that enough space is available for cartridge (filter element) replacement and that the clogging indicator is in a easily viewable position. If an electrical indicator is used, make sure that it is properly wired. Never run the system without the cartridge fitted. We recommend the stocking of a spare FILTREC cartridge for timely replacement when required.

Maintenance

Before unscrewing the cartridge, ensure that the system is switched off and there is no residual pressure in the filter.

Unscrew the cartridge by turning it anticlockwise. Verify the correct part number of the FILTREC replacement cartridge, particularly concerning the micron rating. Ensure that the mounting face is clean, lubricate the gasket on the replacement cartridge prior to assembly. Spin on new cartridge until it reaches the mounting face and tighten for 3/4 turn.

Operation

Make sure that the filter works within the conditions of pressure, temperature and fluid compatibility given in the first page of this data sheet. The cartridge (filter element) must be replaced as soon as the clogging indicator signals at working temperature (in cold start conditions, oil temperature lower than 30°C, a false alarm can be given due to oil viscosity). If no clogging indicator is mounted, make sure that the cartridge is replaced according to instructions on the ca or to the system manufacturer's recommendations.

PED Compliance

FA-2 filters conform to PED 97/23/CE norm, article 3 section 3, and so they can be used with fluids of group 2 (liquids with steam pressure < 0,5 bar at the maximum allowable temperature, article 3, section 1.1(b) – sub-section II).

WARNING

Make sure that Personal Protective Equipment (PPE) is worn during installation and maintenance operation.

Disposal of filter elements

The used filter elements and the filter parts dirty of oil are classified as "Dangerous waste material": they must be disposed according to the local laws by authorized Companies.



FA-2 series

www.filtrec.com



Technical information may change without notice